

# UNE INTERVENTION LIMITÉE SUR L'EXISTANT

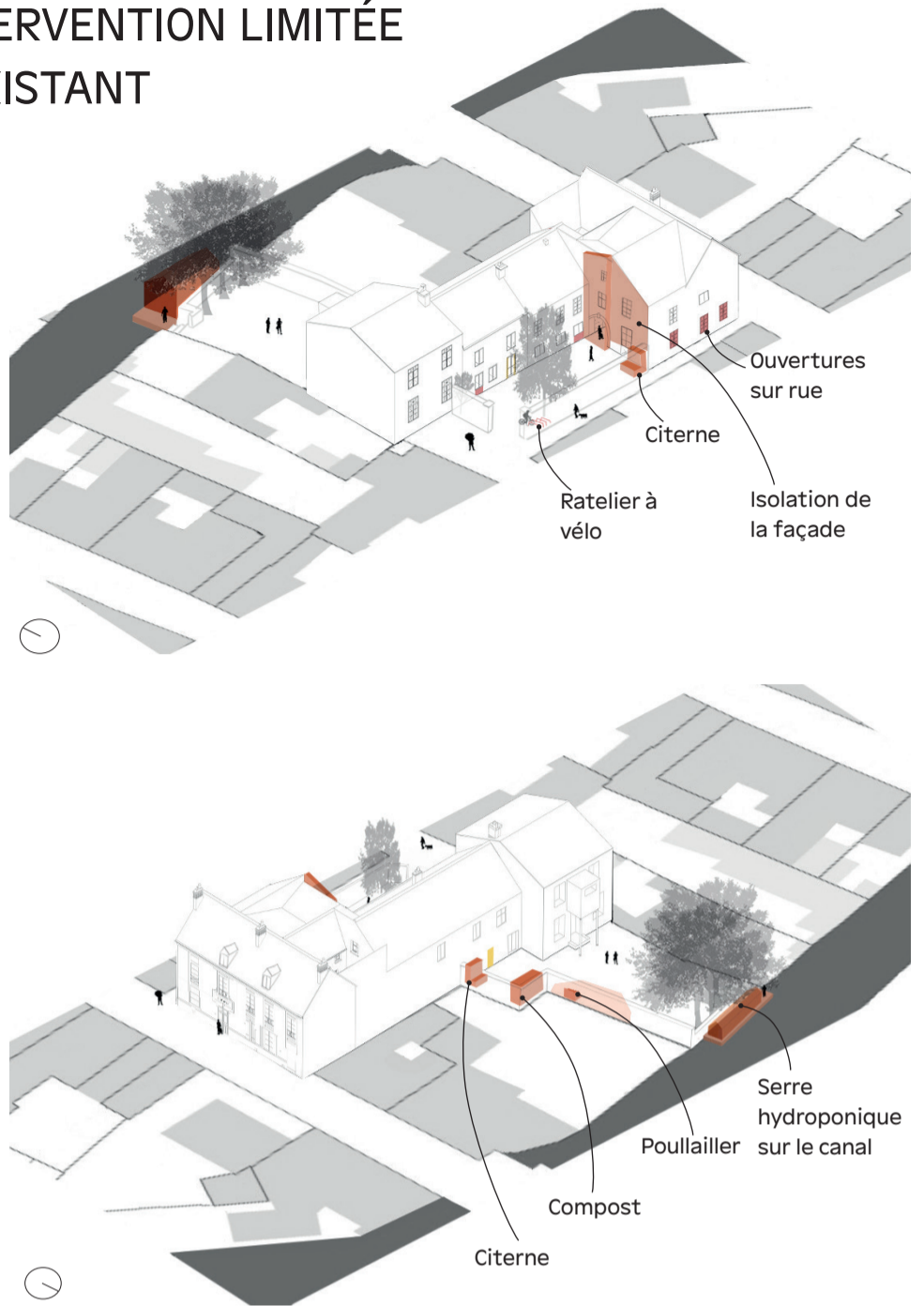

# INTERVENTION SUR LA FACADE OUEST

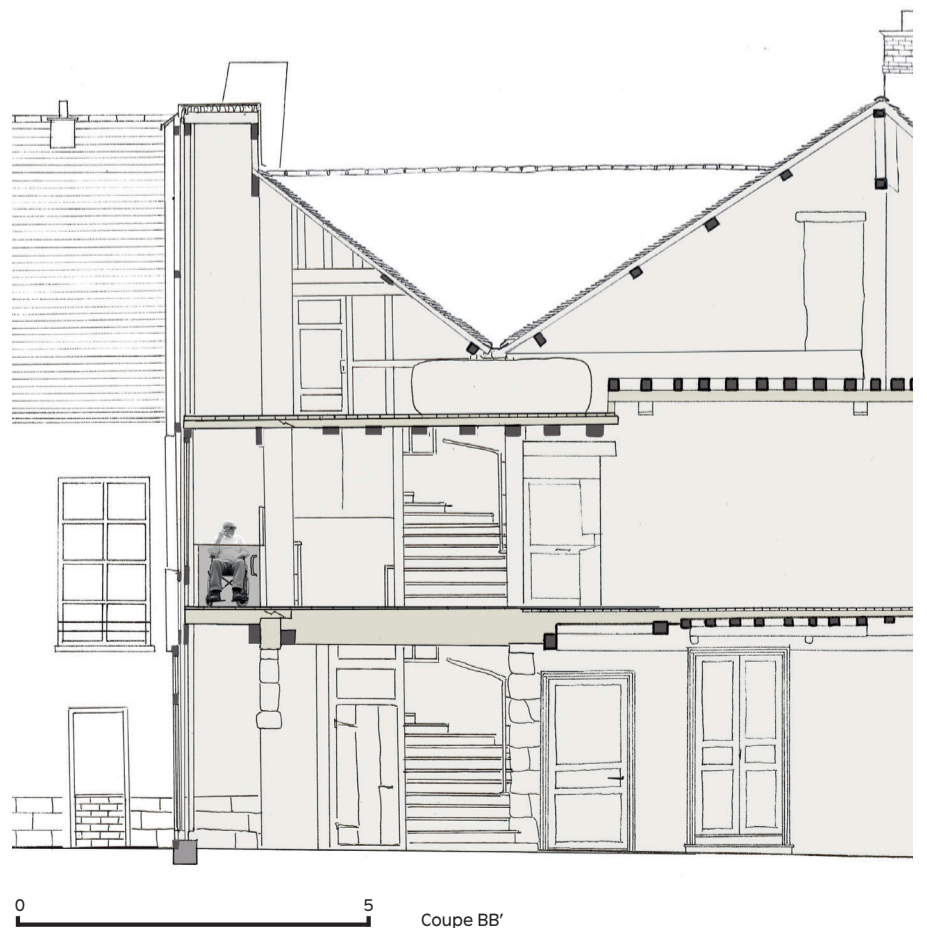
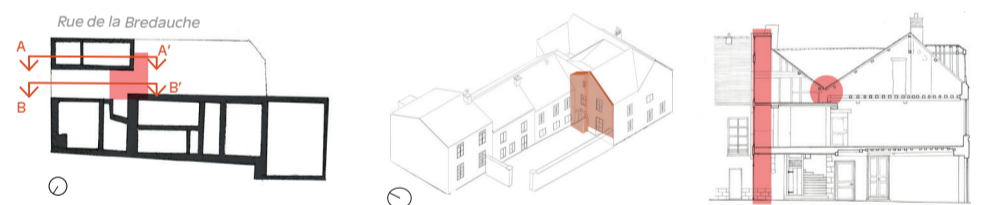
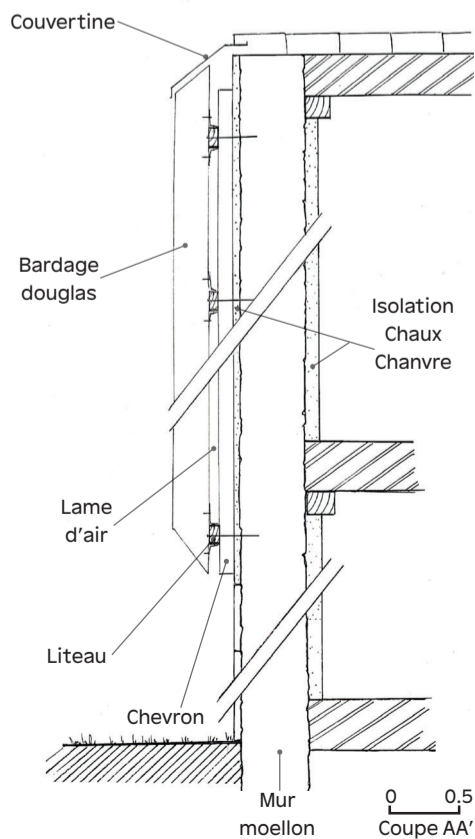
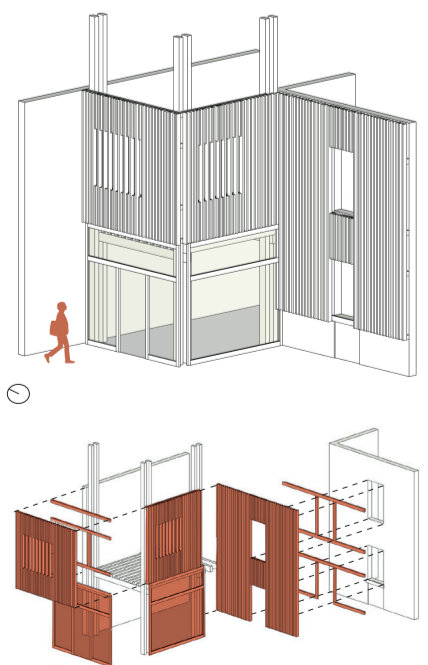
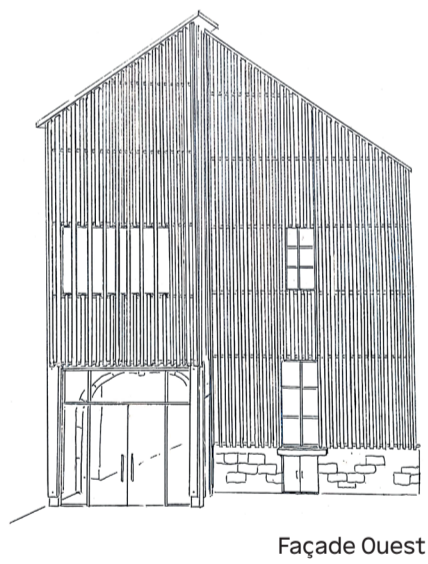

# INSTALLATION D'UNE SERRE HYDROPONIQUE SUR LE CANAL DU LOING

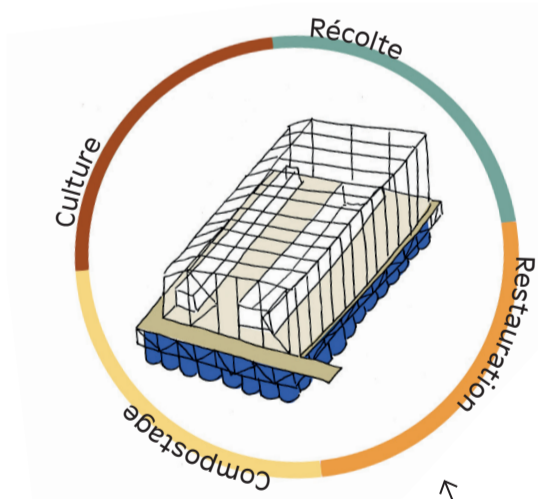
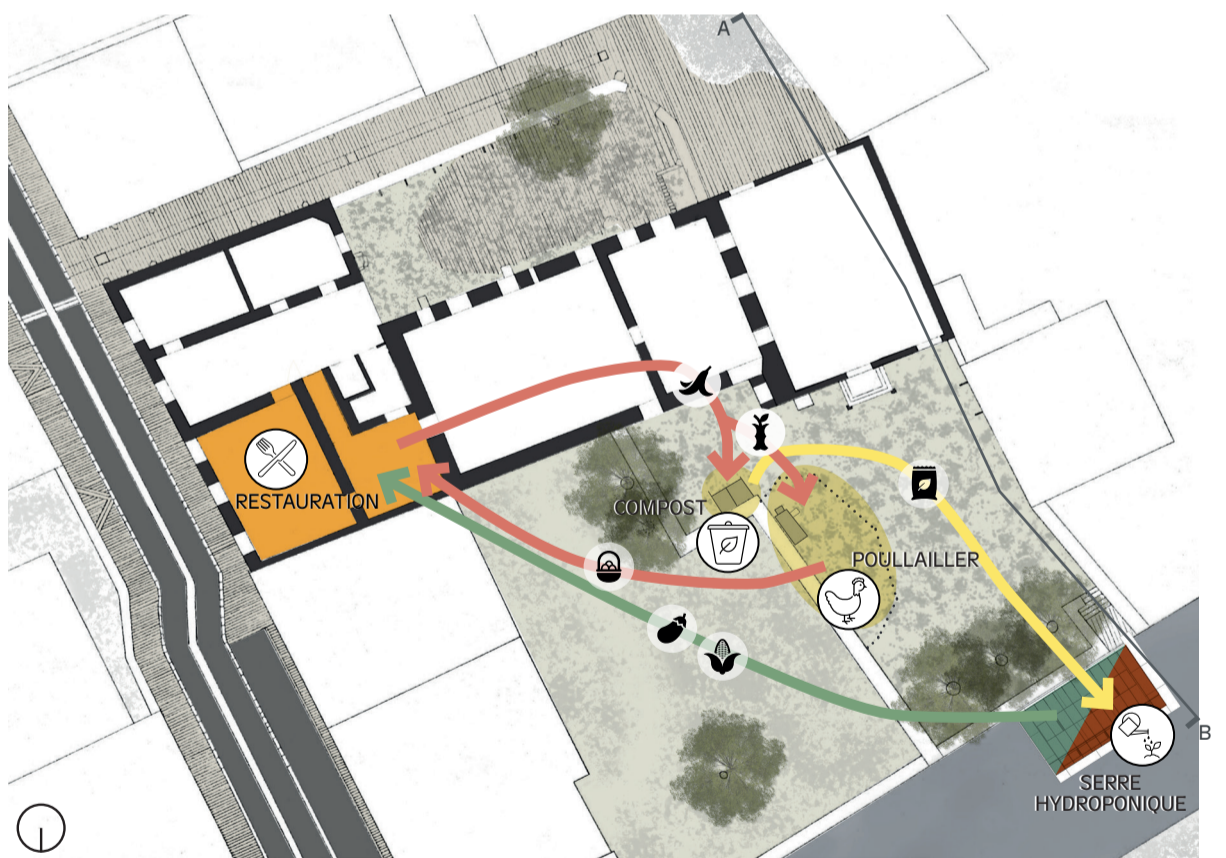
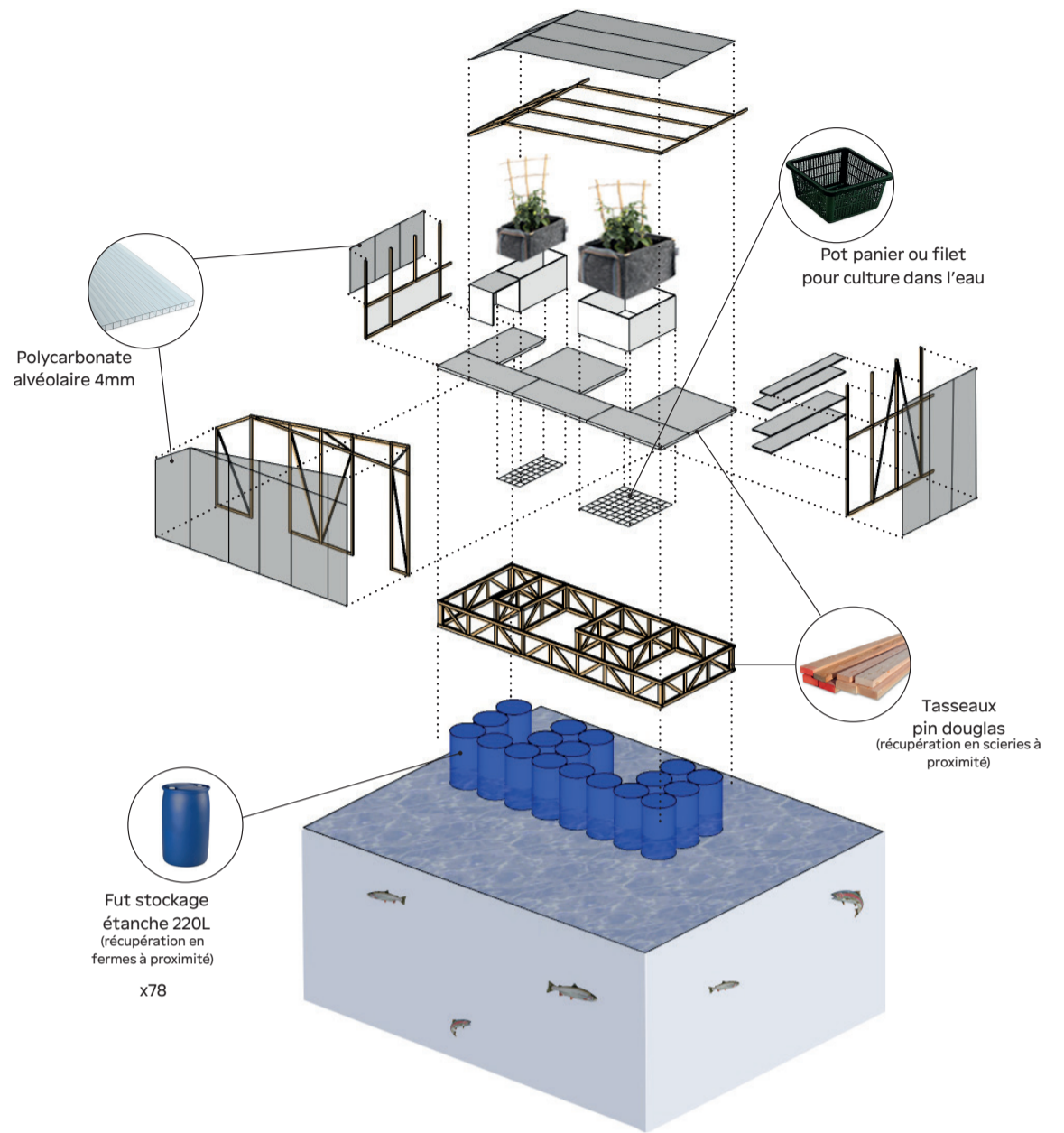
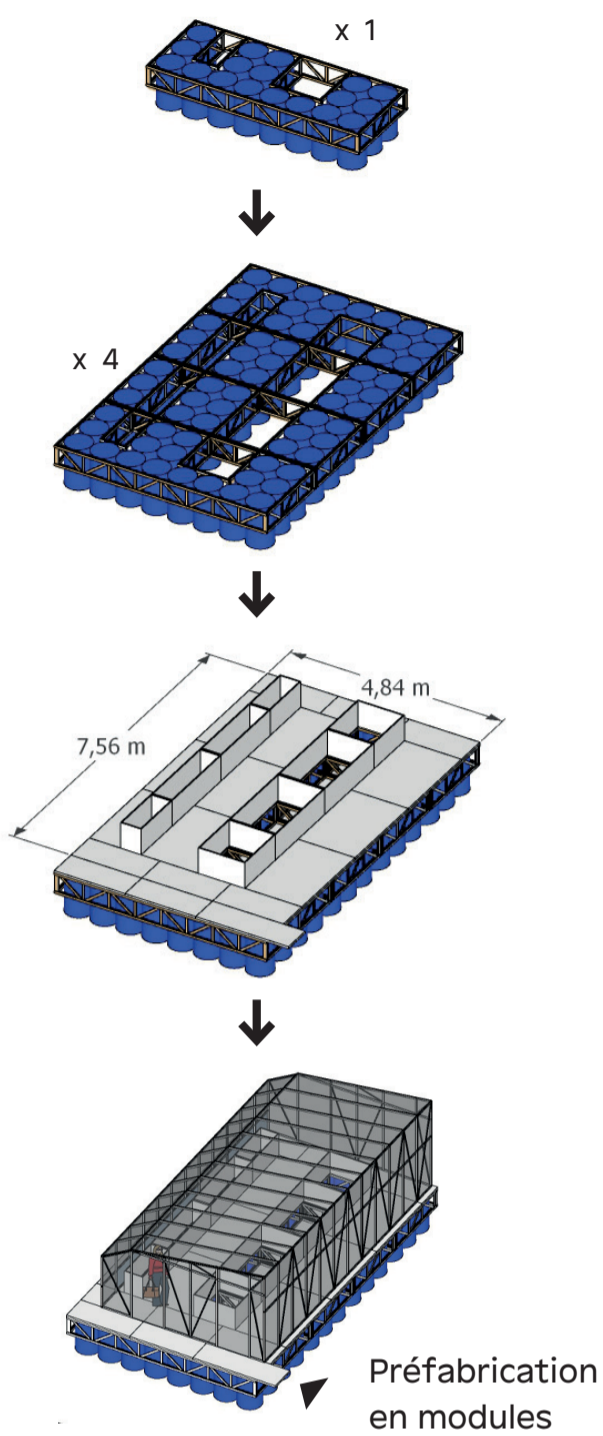

0 10

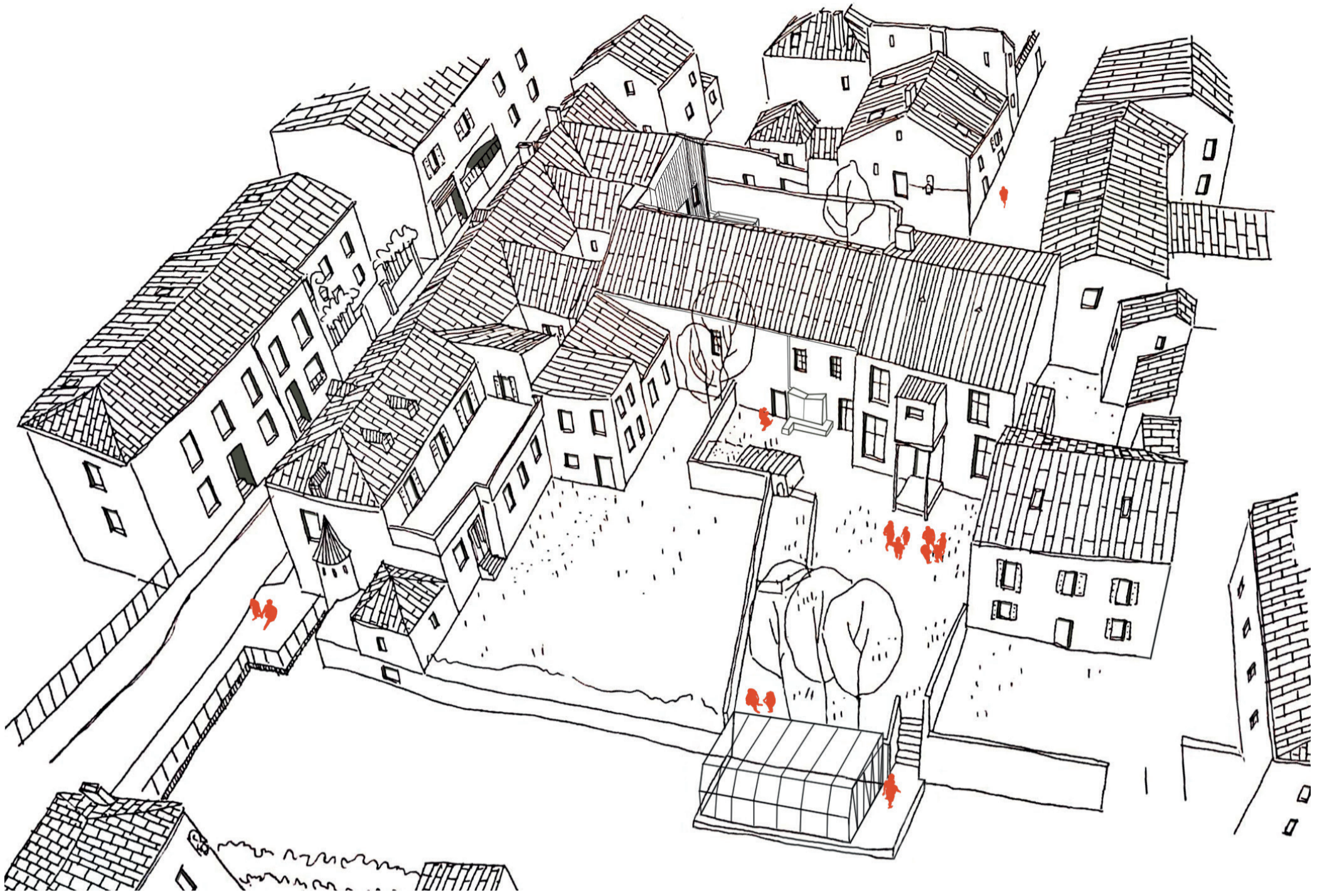

# SALLE DE PROJECTION : OPTIMISER L'ESPACE TOUT EN FAISANT SIGNAL SUR LA RUE

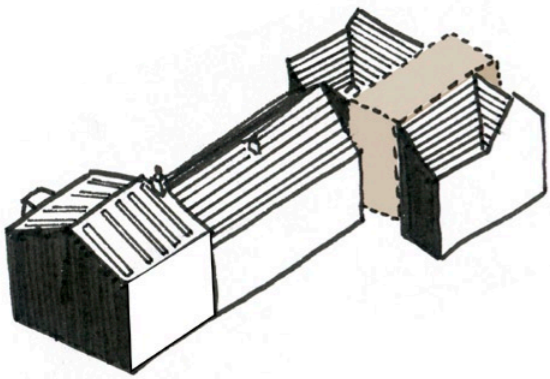
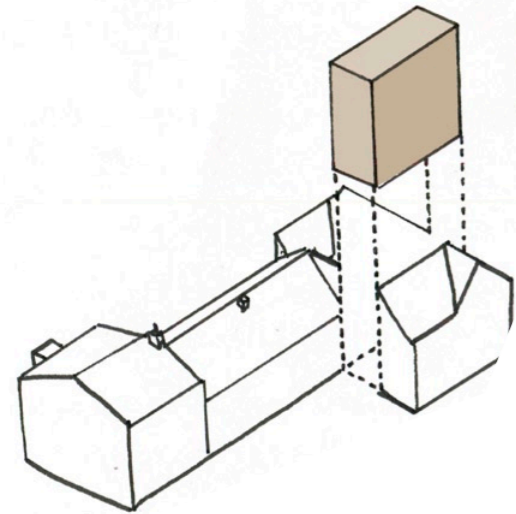
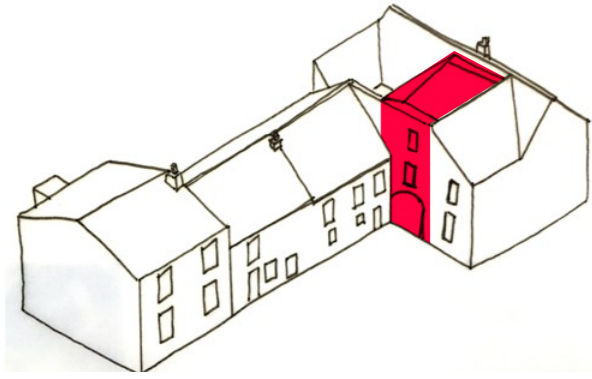

ELEVATION FAÇADE EST

0 3 6m



PERCEPTION DEPUIS LA RUE DU DOCTEUR DUMÉE



SCHÉMA AXONOMÉTRIQUE DE PRINCIPE

# UNE SCÈNE OUVERTE

ENCHASSER UN NOUVEAU VOLUME, EXTRUDER L'EXISTANT POUR L'OUVRIR SUR LE PAYSAGE ET ADAPTER SES CAPACITÉS

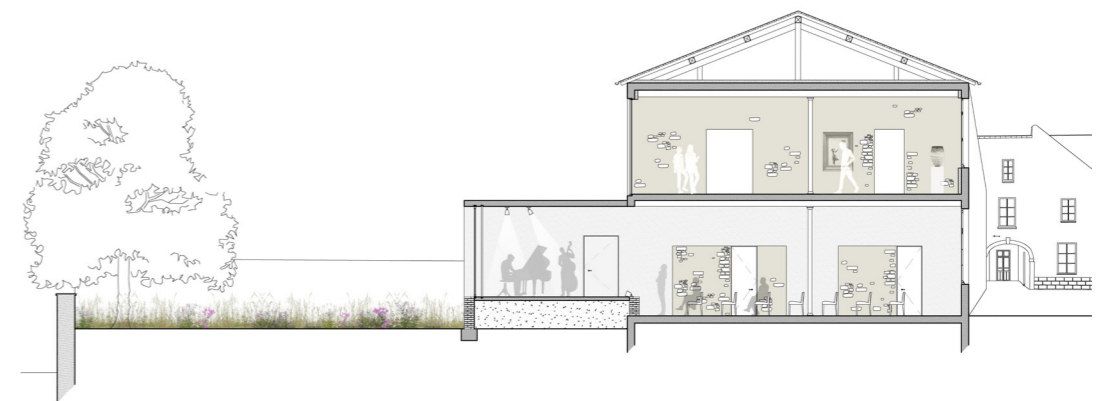
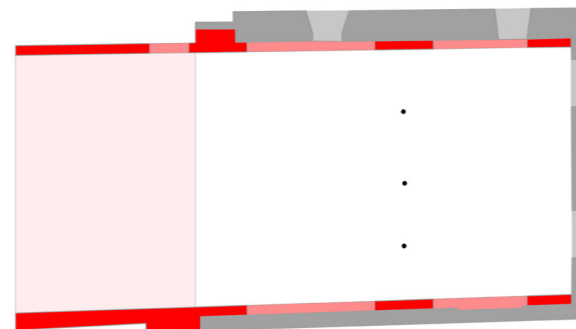
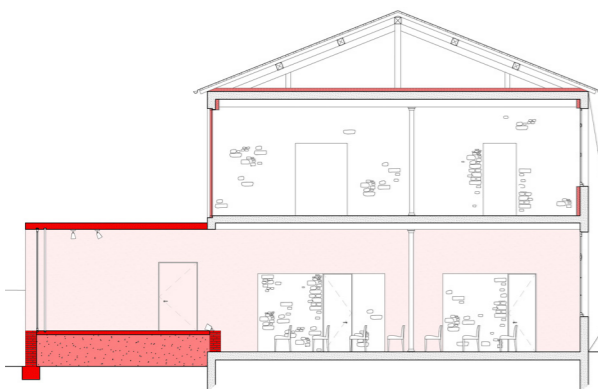
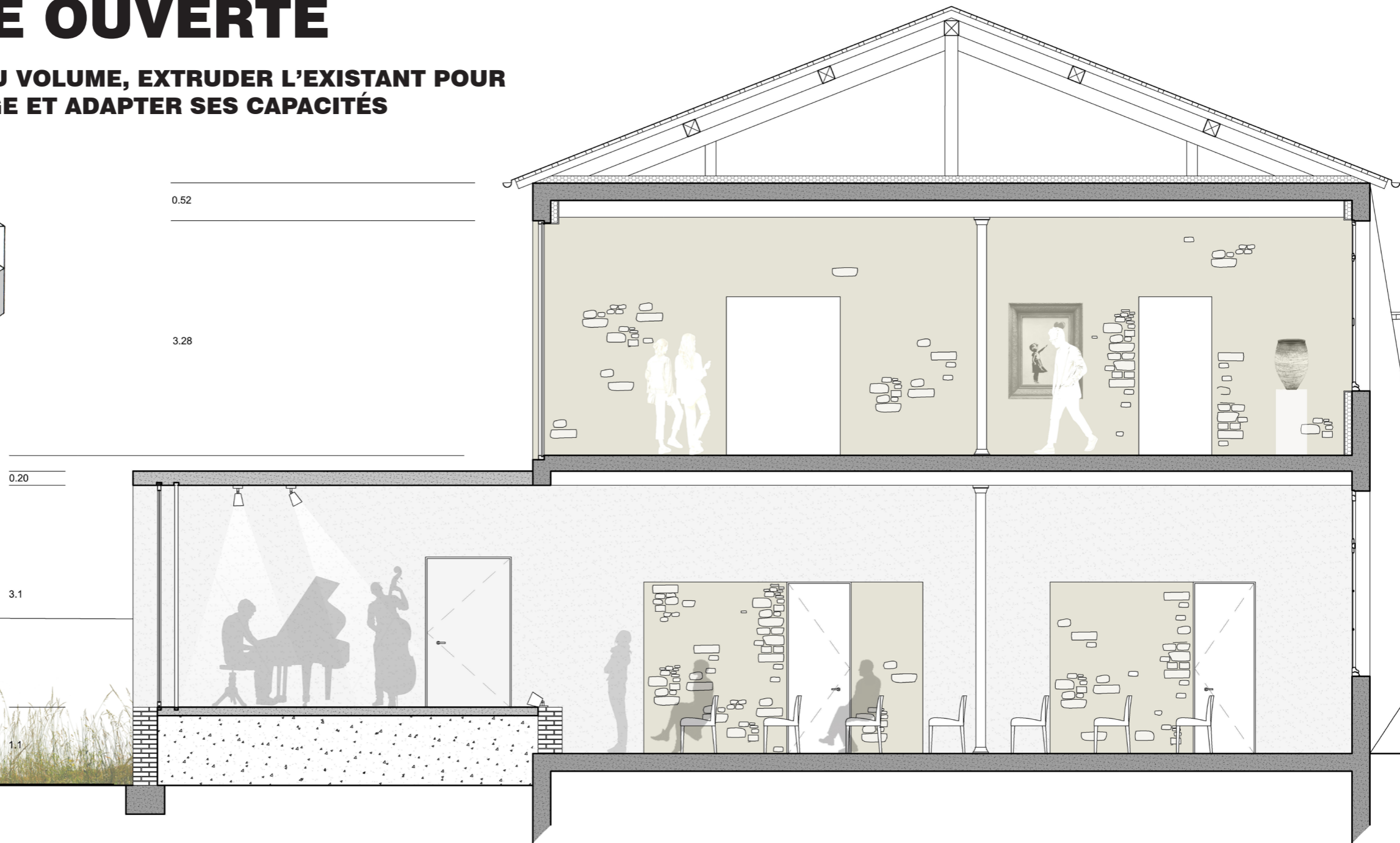
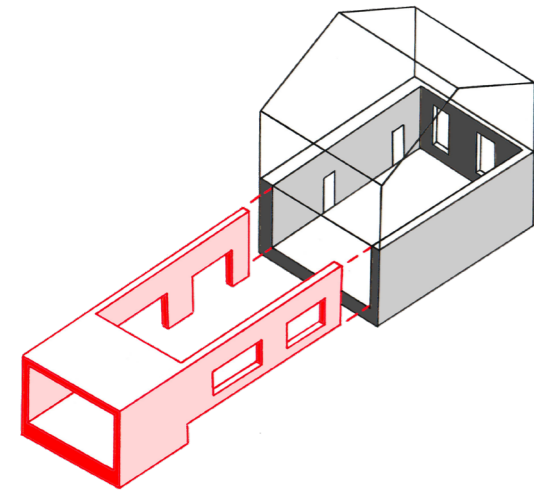

Extension insérée dans le volume existant, une nouvelle épaisseur doublant le mur

# DES ATELIERS OUVERTS SOUS LES COMBLES

UNE EXTENSION LÉGÈRE QUI AUGMENTE ET OUVRE LES COMBLES EN PRÉSERVANT SA CHARPENTE

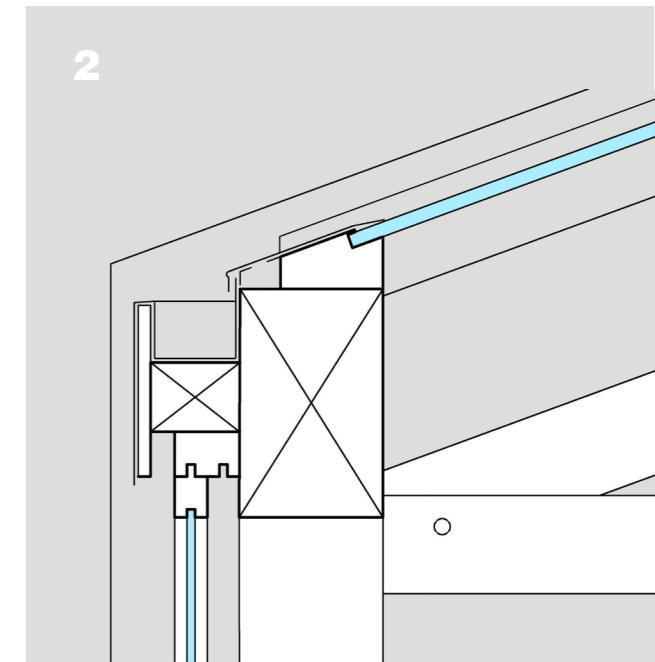
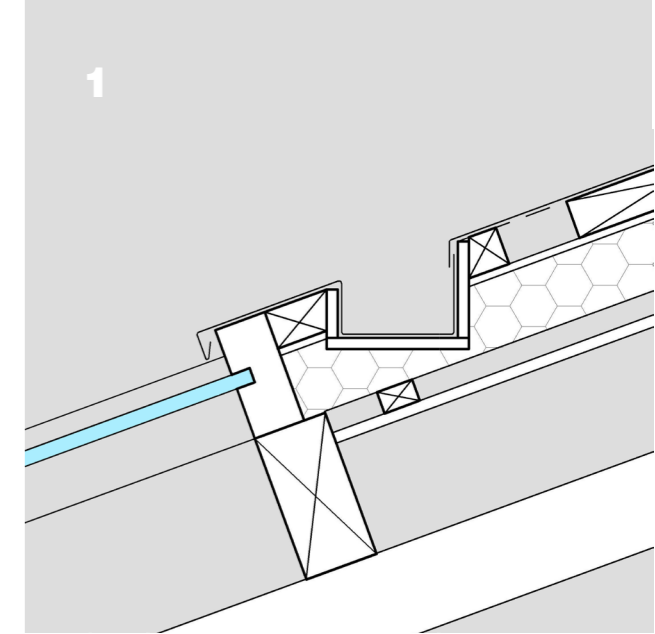
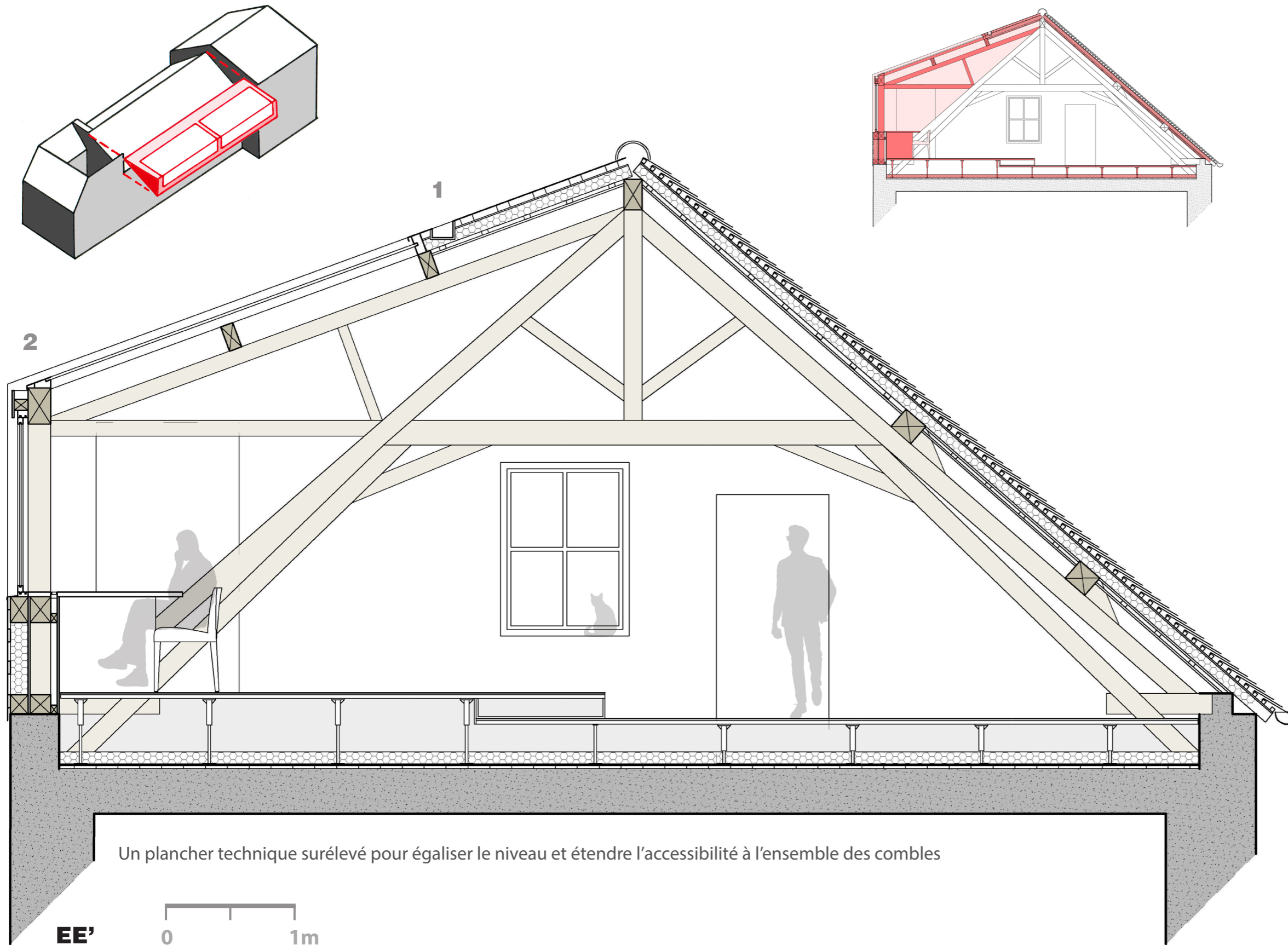

0 10 20 cm

ascenseur escalier XVIIIe

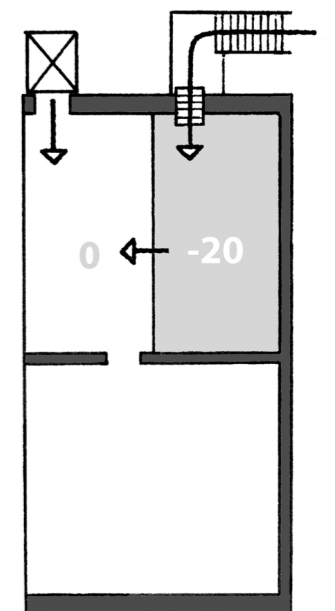

# La Jardin et ses modules

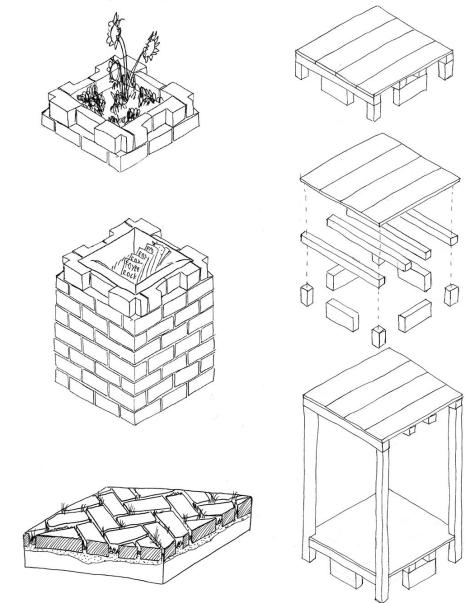
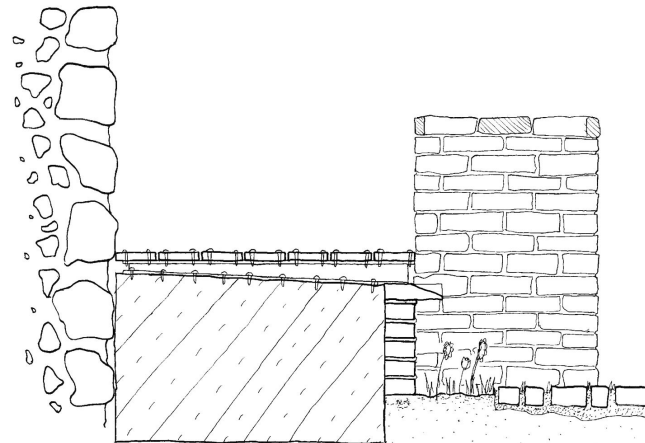
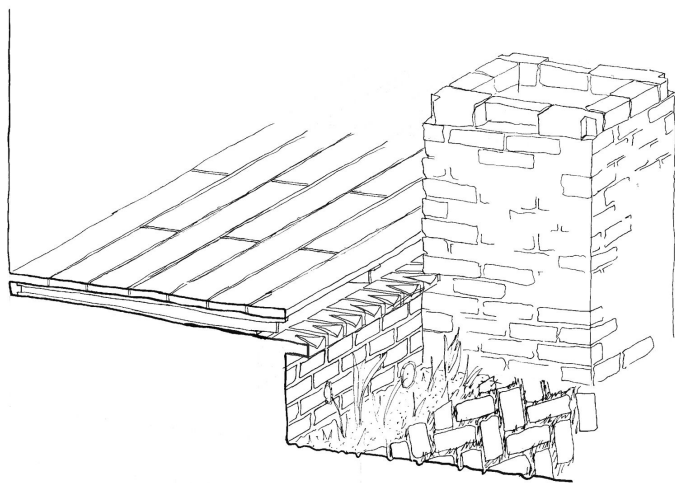
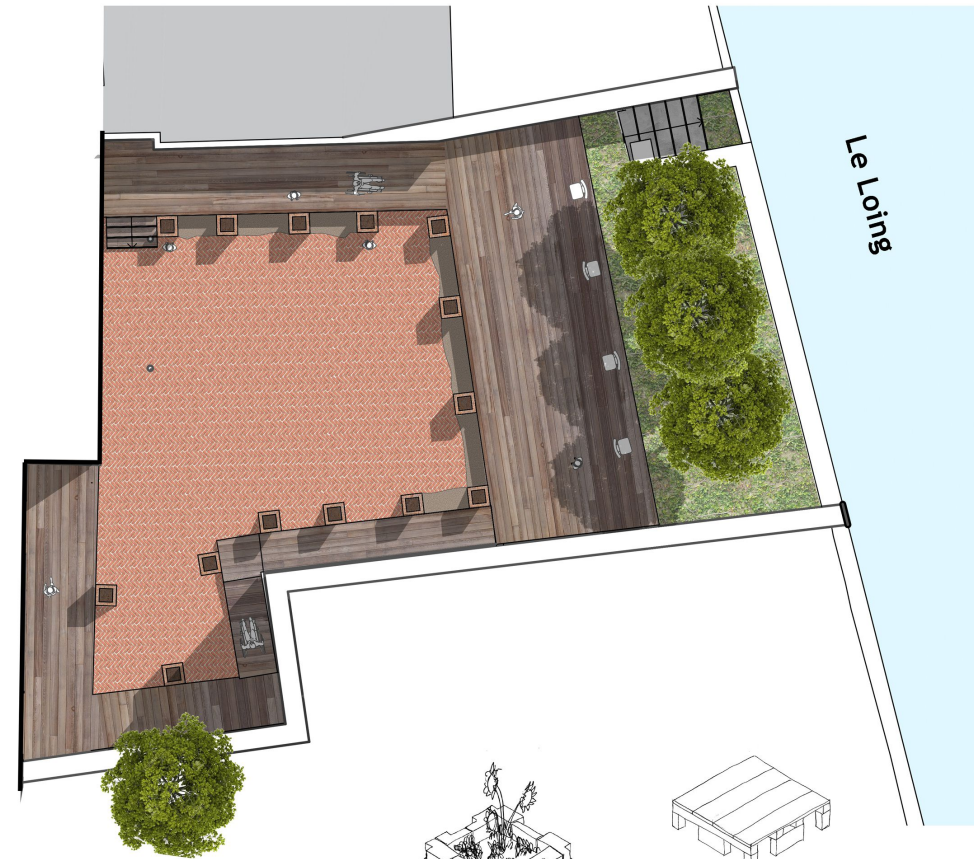

Corentin BOURGEOIS

Jury 20/01/21

Mirabelle Croizier

# Salle d'exposition

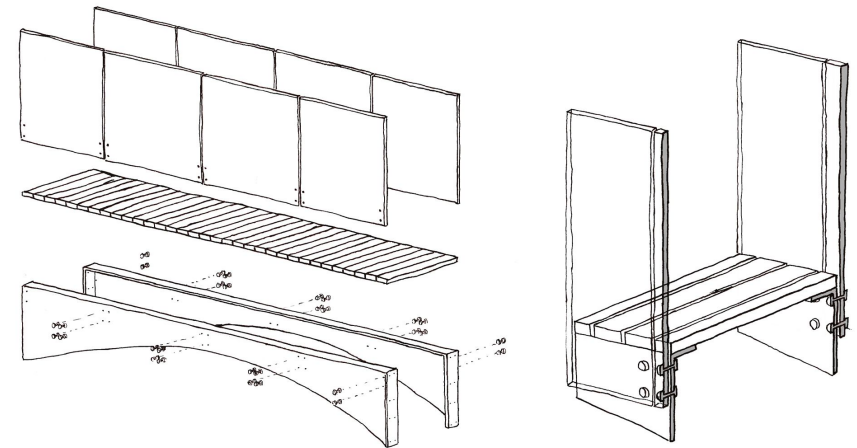
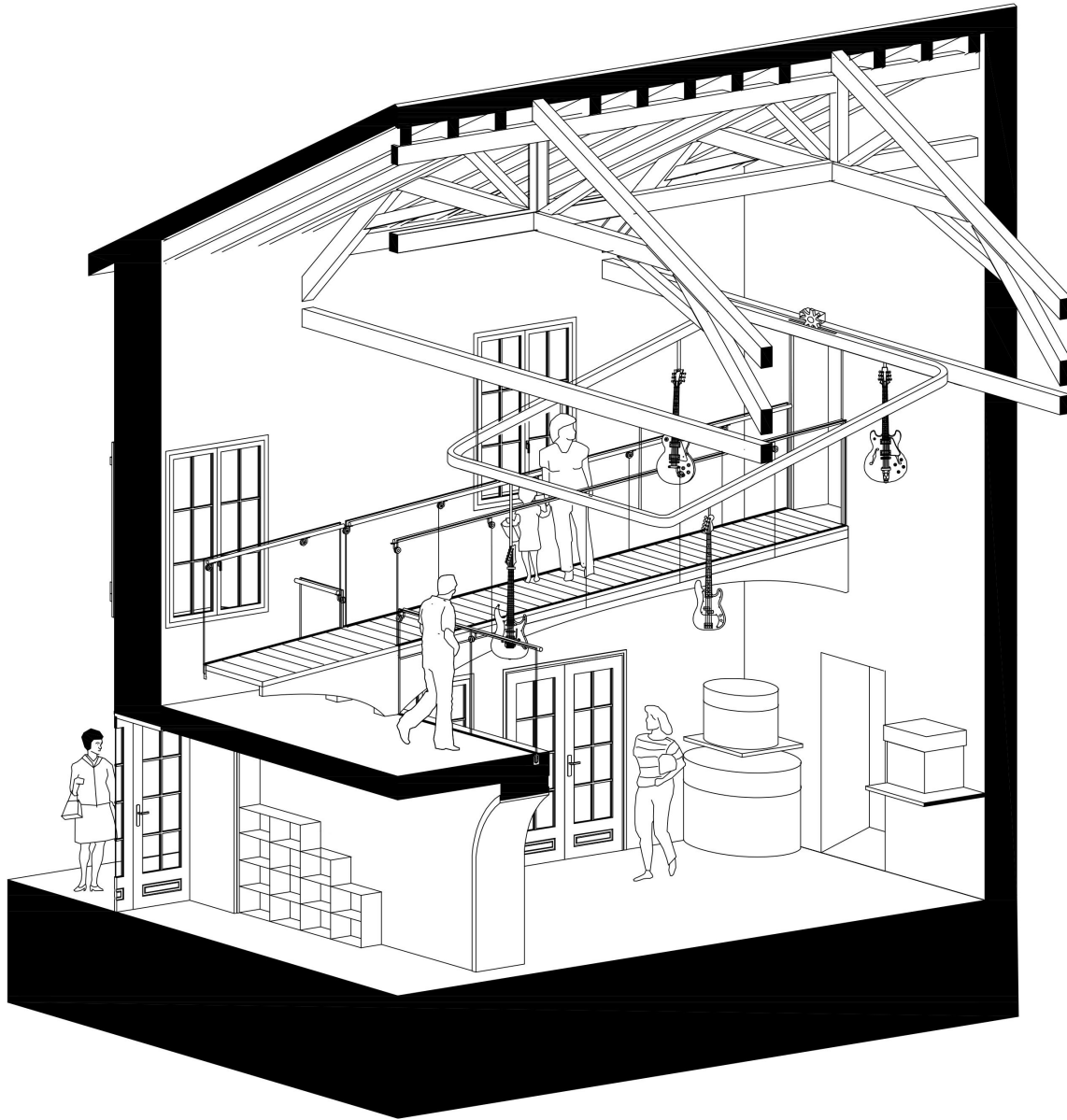

Corentin BOURGEOIS

Jury 20/01/21

Mirabelle Croizier



## Usages et apparition de la « ligne de vie »

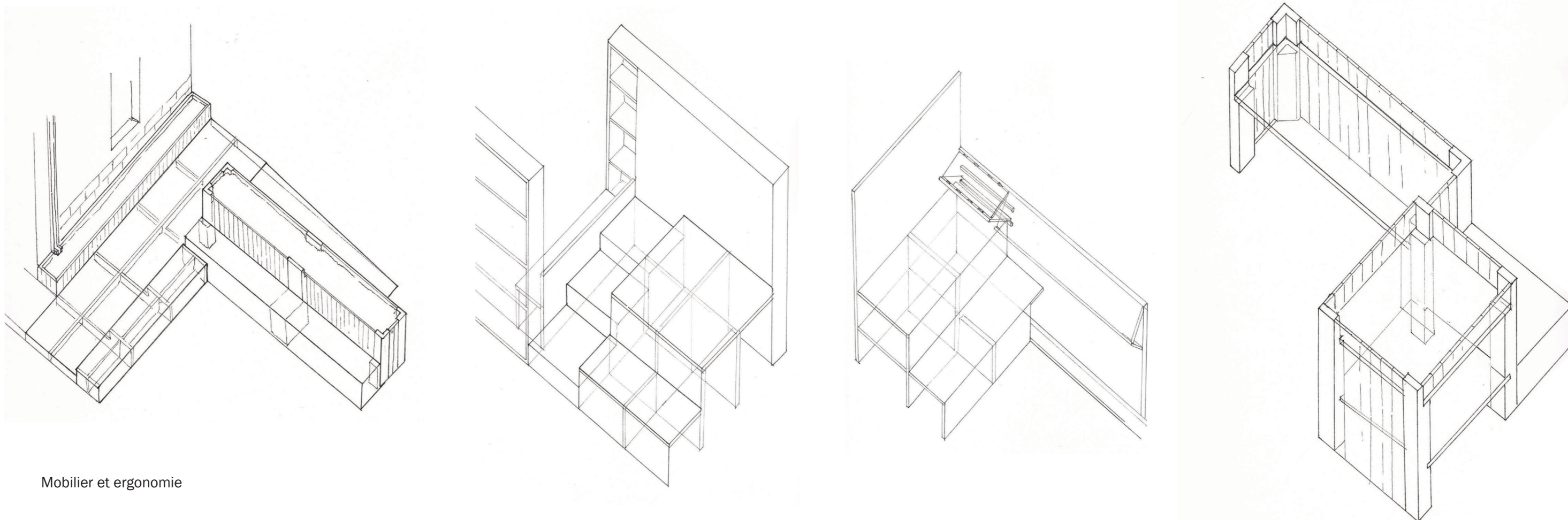

Mobilier et ergonomie

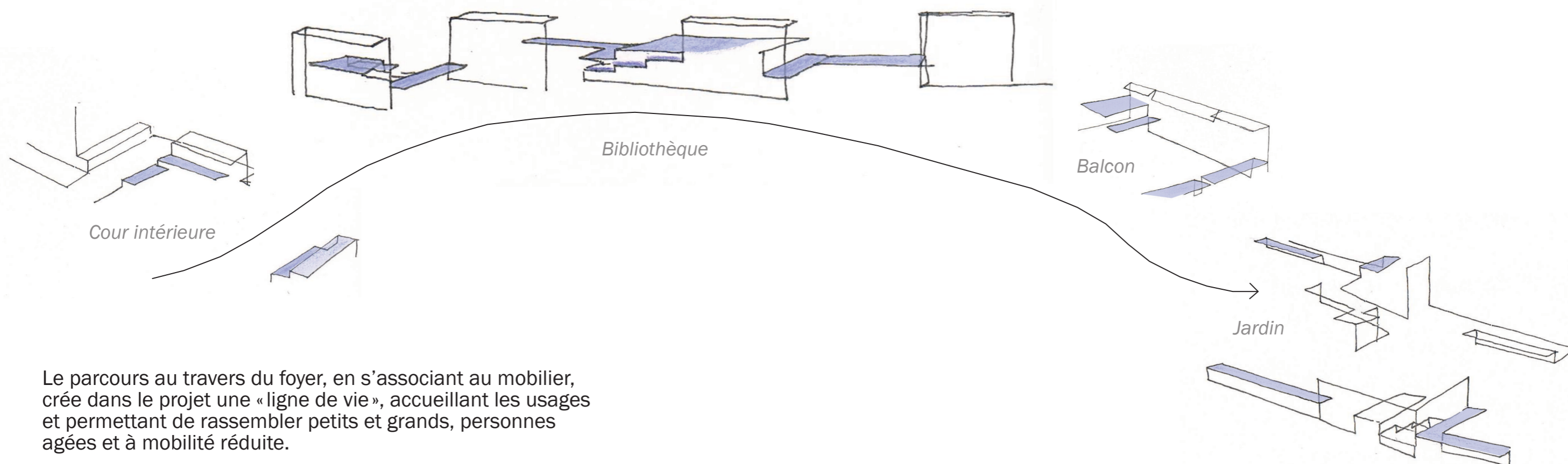

Le parcours au travers du foyer, en s'associant au mobilier, crée dans le projet une « ligne de vie », accueillant les usages et permettant de rassembler petits et grands, personnes âgées et à mobilité réduite.

# L'espace majeur du projet

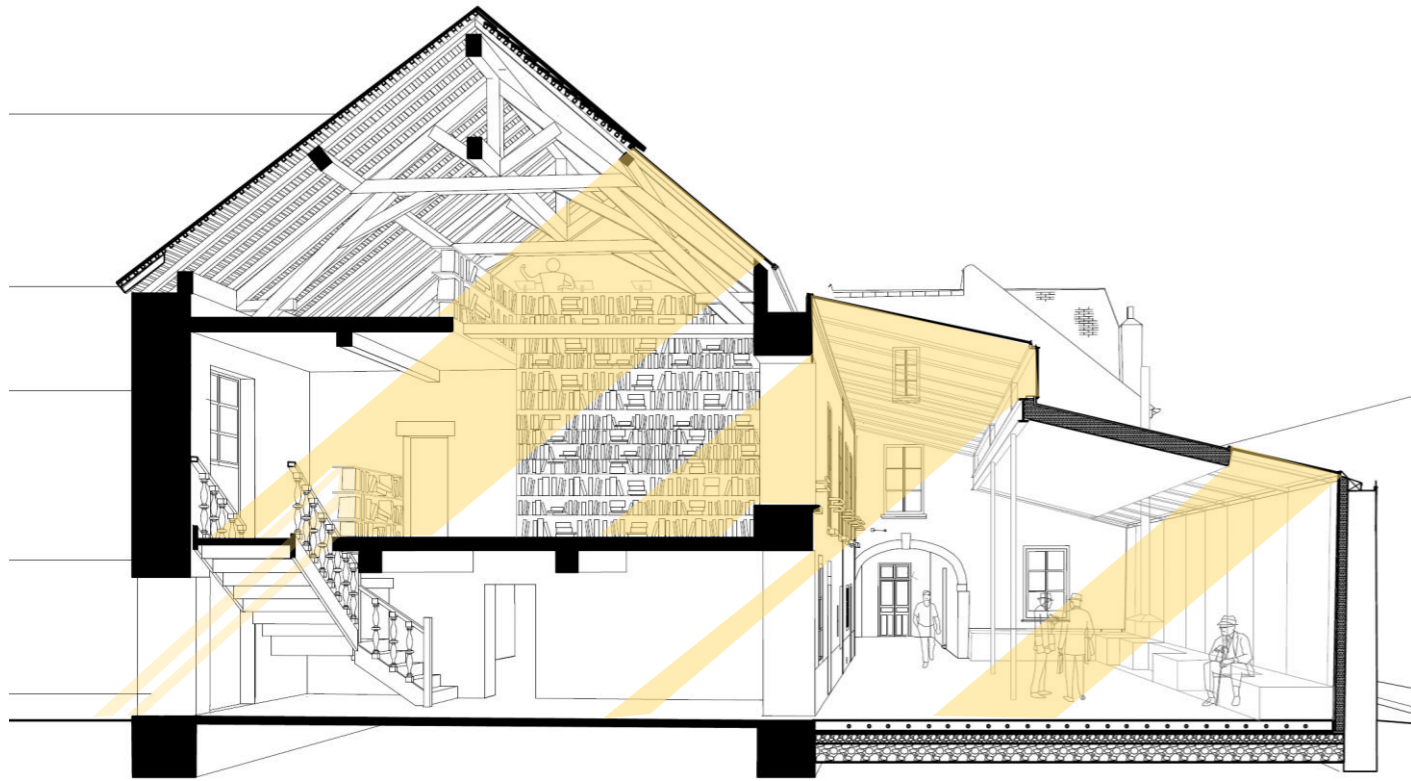

Étude de la lumière filtrée par le système de verrière

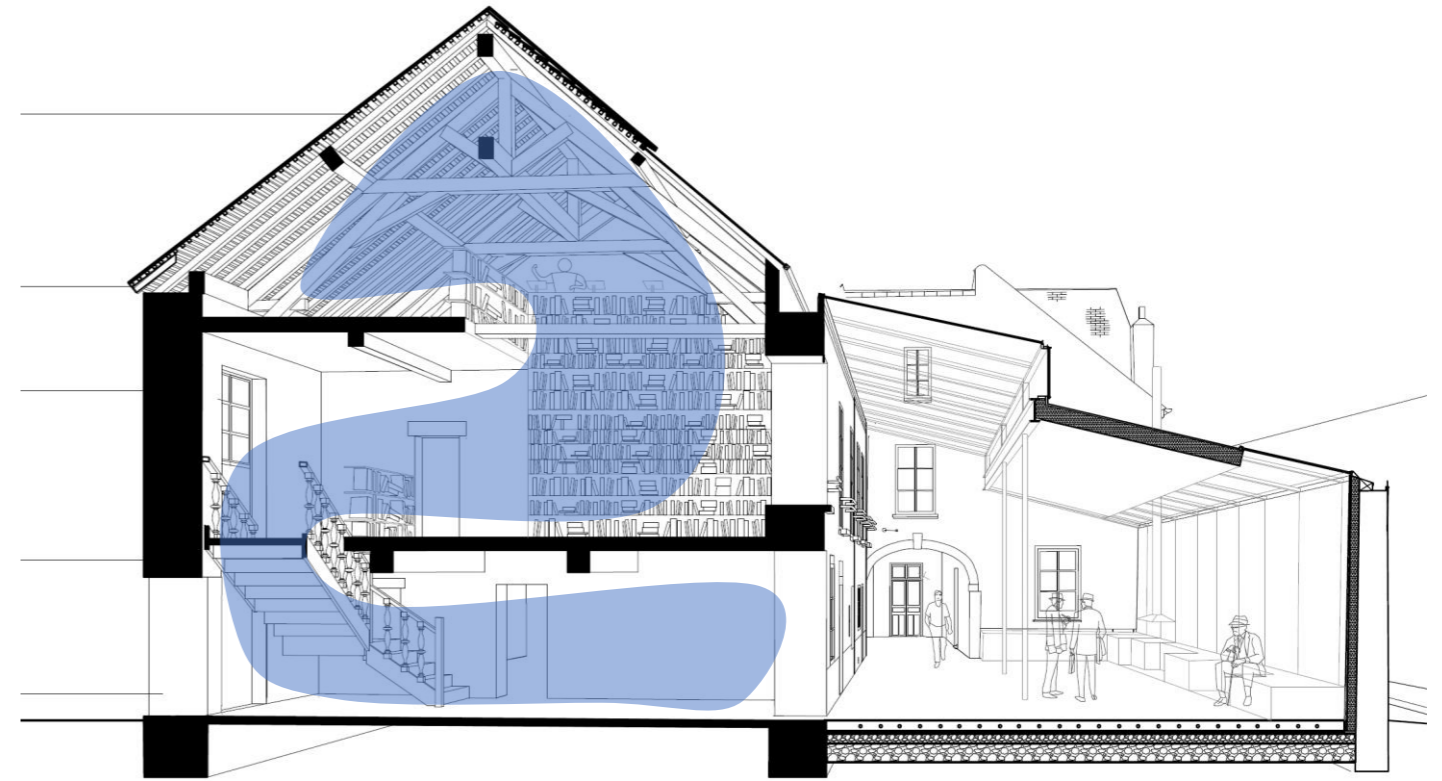

La bibliothèque, trois niveaux qui se répondent

## Sous la serre: un espace capable L'occupation de l'espace varie selon les heures de la journée et les jours de l'année

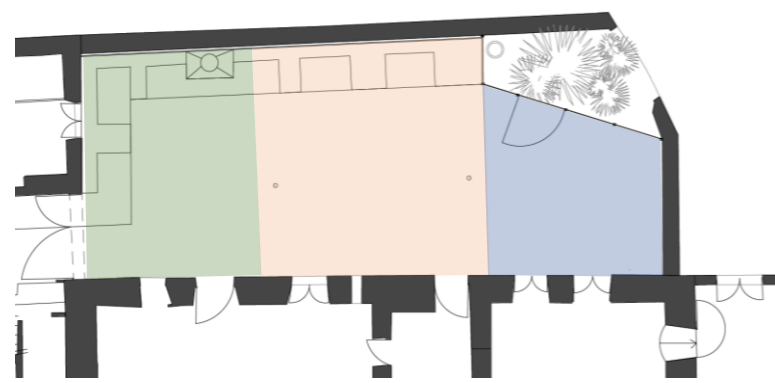

Lundi midi

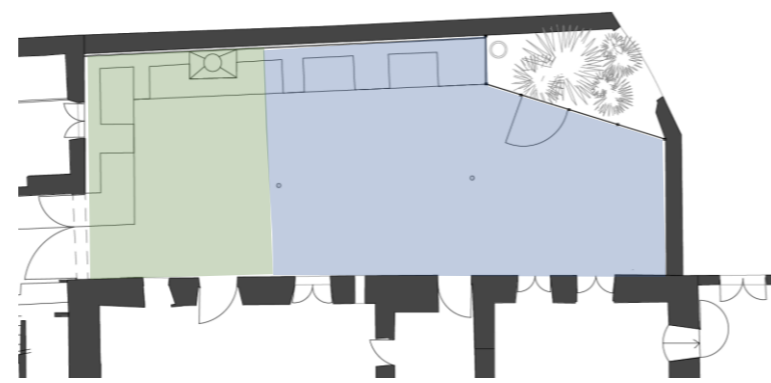

Mercredi matin

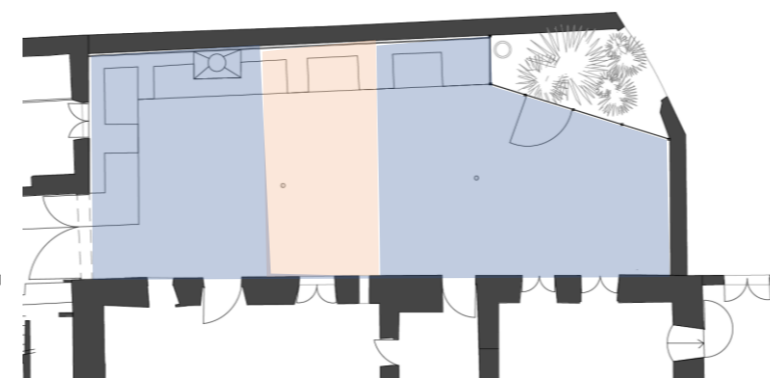

Samedi soir

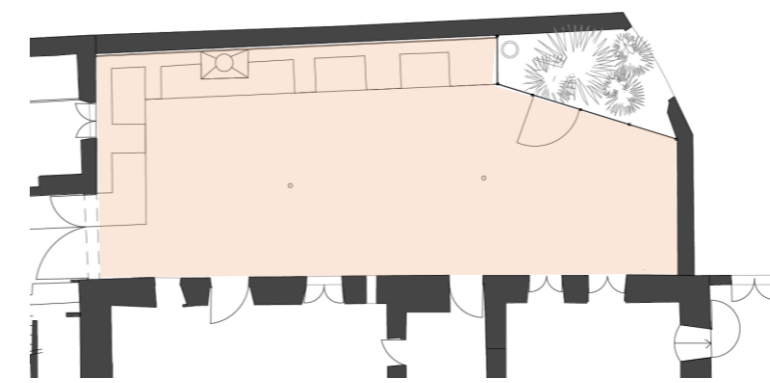

Jour de fête

Salle d'attente

Restauration

Salon, jeux, lecture

... mais aussi d'autres usages à inventer